

Pure Sinewave Inverter 2000VA



Pure sinewave



Digital display



Transfer switch



Remote control port



High frequency technology



Extended temperature range



Multiple electronic protection

Applications

- Telecom Power Plants
- Marine & other rugged environments
- Electric Utilities and Substations
- Base Station Power
- Industrial Controls
- Solar Home Systems
- Fuel Cell Applications
- Solar / Alternative Power Systems
- Emergency Power Backup (UPS)
- Pleasure and holidays
- Development aid

Sinewave Inverter

Series PSW2000-1U

Description

The model PSW2000-1U pure sinewave inverter supplies a 230VAC output voltage either from a 12V, 24V, or 48 VDC power source. The shape of the output voltage is pure sinewave - as from the grid.

All new High Frequency Switching Design offers high power and reliability in a compact package and light weight. Extra input and output filtering reduce EMI to extremely low levels. Reliability features include an input fuse, thermal shutdown, current limiting and output short circuit shutdown with automatic recovery.

The input and output is fully isolated.

The superb overload capability supplies short time peak power to start heavy equipment such as pumps and compressors.

The unit is equipped with an automatic bypass function < 6ms.

Optional: Remote Control

Ruggedizing (against shock and vibration)

Features

- Pure sine wave output (THD < 3%) R Load
- No derating of output power up to +50°C
- By pass function 4-6ms
- Isolated Alarm Contact
- Output voltage / frequency selectable
- RS-232C interface / remote controls port / Wire connection to PC
- Compact design, low profile
- Temperature and load controlled cooling fan
- Advanced microprocessor
- Protection: Input low voltage, Input over voltage, Short circuit, Overload, Over temperature
- Low battery alarm
- Digital display: VAC, VDC, AAC, Watts, Temp, Frequency
- Low ripple on the DC-Input to save battery life time
- 24 month parts and labour warranty

Block Diagram

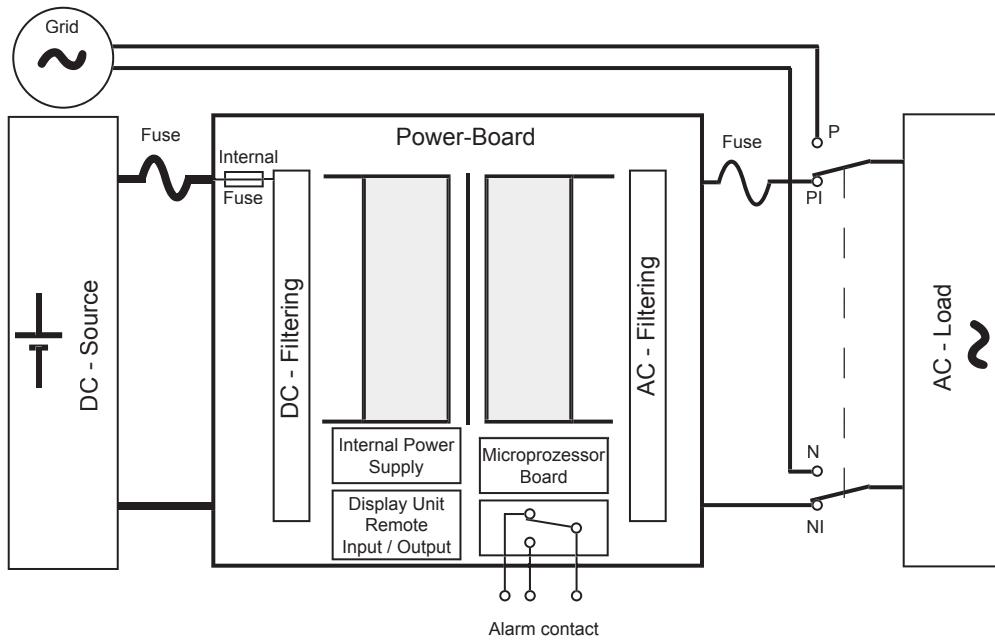

Specifications (Specifications Subject to Change Without Notice)

Electrical (output)

Nominal VAC	200 - 220 - 230 - 240 (selectable) +/- 3%
Output Frequency	50Hz - 60Hz (selectable) +/- 0.05%
Nominal power	1700W (2000VA) continuous
Power for 1 min.	1870W
Power for 20 sec.	2040W
Output Waveform	Pure Sinewave <3% THD (R Load)

Environmental Specifications

Operating Temp. Range	-30° to +60°C @ maximum output > 50°C derating 2% per °C Thermal Shutdown @ +90°C
Humidity	0 - 95% Relative Humidity (non-condensing)
Audible Noise	Scarcely audible @ 1m (Fan OFF)
Fan	Load and temperature controlled
Isolation	Input-Output 1100VDC, Input-Case 1100VDC Output-Case 500VDC
Indicators/Display	VDC, VAC, AMP, WATT, Hz (selectable)
Alarm Indicators	OVP, UVP, OTP, OLP
Isolated Alarm Contact	Switching capacity 120VAC/5A , 30VDC/2A
Protection	Short circuit, Overload, Overtemperature, Overvoltage, Low voltage

Electrical (input)

Nominal voltage (VDC)	12	24	48
Voltage range (VDC)	10 - 16	20 - 32	42 - 64
Amps @ Pnom (A)	188	92	46
Idle current 230V ON (A)	1.47	0.8	0.47
Efficiency max.	91%	93%	95%
Efficiency @full load	87%	90%	92%
Bypass AC Input (VAC)	180 - 260		
Bypass Frequency (Hz)	50 - 60		
Bypass Amps (A)	15		
Bypass (ms)	4 - 6		
Interface Control Port	RS-232C With Baud Rate 2400,4800, 9600, 19200 (Switch Selectable)		

Mechanical Specifications

Length	45 cm
Width	19"
Height	1U (4.4 cm)
Finish	Black Anodize / Powder Epoxy Coat
Weight	7.5 Kg
Connections	DC-clamps, AC-connector IEC60320-1 (Connector supplied with Inverter)
Warranty	2 years
Standards	Approval to CE

RoHS Compliant
Directive 2002/95/EC

Available from:

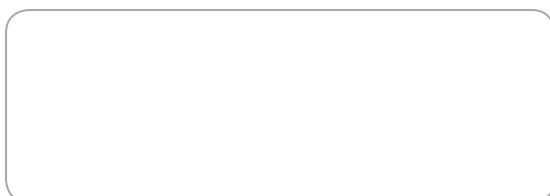

RIPEnergy®

The power conversion company

RIPEnergy AG
Wägitalstrasse 24
CH-8854 Siebnen
Switzerland

Ph +41-(0)43-818 53 85
Fax +41-(0)43-818 53 87
www.ripenergy.ch