



**RIPEnergy**<sup>®</sup>  
The power conversion company

**POWERCube** by RipeEnergy is a power station unit for remote areas. Every **POWERCube** is designed and programmed to meet exactly the demand of power you need. The team of RipeEnergy AG has more than 20 years of experience in renewable energy systems and component design. To make out the best possible value for your customer our team will work close with you from the very beginning of system design. This enables us to design each **POWERCube** to optimize efficiency, reliability and price according to your needs. To make it long lasting, low service demanding it is installed in a heavy duty, lockable cube protecting your expensive equipment perfect from wheater, heat, humidity, mechanical damage and theft.



**POWERCube** delivers reliable clean power such as pure sinewave AC-Power or DC-Power as it is required for you application. The system size starts at 2KW single phase but there is no limit up to 30KW for single phase systems or 15KW for 3 phase systems. It can include additional control units as MPPT (Maximum Power Point) charge controllers for solar modules, wind turbines, fuel cell applications and many more. It can be combined with generators, fuel cells and other modern power sources. Depending on the available power source the system is designed using the latest technology for energy storage such as LiION batteries, Fuel Cells, Redox Flow, AGM or conventional batteries.

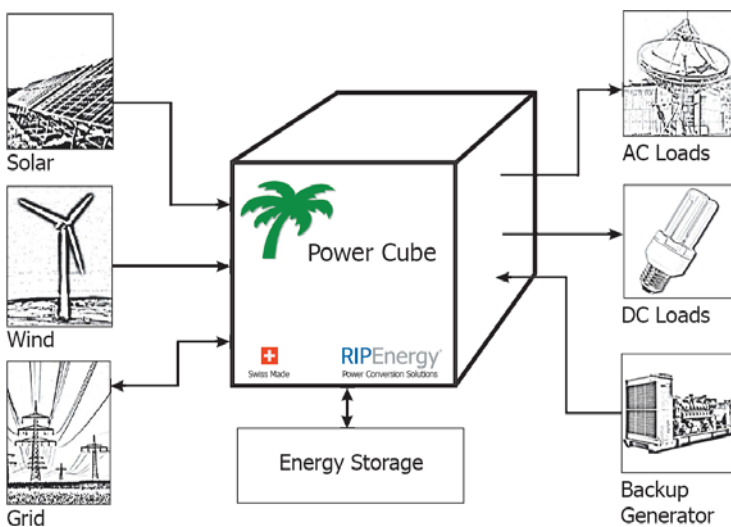

The design is focused on a rugged, reliable, low maintenance, effective and affordable power system. System means that **POWERCube** comes completely assembled with all DC and AC power breakers, Lightning protection, FI-Switches or string box wiring if required. We will do all necessary programming of the system before delivery. It is real plug and play! You need more power in the future? As the design of **POWERCube** is on a modular base, it can be upgraded to meet future power demands when necessary.